



920 CPU HOLDER

PROTECTION, ADAPTABILITY, FLEXIBILITY

As CPU's get smaller, their safekeeping becomes more critical. The 920 CPU Holder's exclusive 3 point security protection system features two keyed locks plus tamper resistant screws on the track for the ultimate in protection.

The 920 CPU Holder's super slender 1¼" width takes care of today's slim form factor units and can easily expand to fit larger mini towers. For added flexibility, select from four versions and three mounting options.

Our focus on adaptability extends to environmental considerations. The responsible design uses 30% fewer materials, reducing pressure on natural resources for manufacturing, shipping and disposal. The materials used are chosen both for their recycled content and easy recyclability.

Let work
come to Life.™

Workrite
ergonomics®



920 CPU HOLDER™

Products listed on this page are available through GSA Contract GSA-28F-0030S SIN #711-2 (Schedule 71)



workcenter accessories

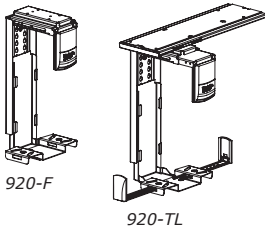

Product features:

- Stylish, modular design accommodates modern CPU sizes from 9¾" to 18½" high, 1¼" to 8¾" wide, 8" to 19¼" deep
- Silver finish on metal components, light gray on plastic brackets
- Height range adjusts in ¾" increments
- Non-Locking versions have no depth limitations and do not have bottom brackets (as shown on 920-F to left)
- Locking version includes adjustable bottom bracket, two keyed locks and tamper resistant screws for track mount
- 16" nylon track allows 10" travel & 360° swivel for easy access to rear of CPU and under-desk storage
- Security lock kit retrofit option available
- Multiple mounting options include fixed wall mount, fixed under desk mount and track mount
- Supports CPUs up to 75 lbs.
- Sturdy steel construction
- Lifetime warranty



Accommodates the widest range of CPU sizes, from 9¾"×1¼"×8" to 18½"×8¾"×19¼".

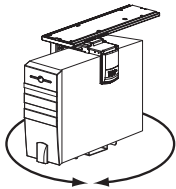

360° swivel on track mounting for easy access to back of CPU.



3 point locking system to protect hardware and data investment.

Environmental considerations:

- Uses 30% less material than comparable products
- Product is minimum 96% recyclable at end of life and easy to disassemble
- Plastic components made from fully recyclable plastic
- VOC free finish
- LEED credit eligibility (1-6 points)
 - Innovation & Design Process, ID Credits 1.1-1.4
 - Implementation of comprehensive ergonomic program (1-4 points)
- Materials & Resources, MR Credit 4.2
 - Recycled content, 20% (2 points)

Specifications: Height, width & depth range

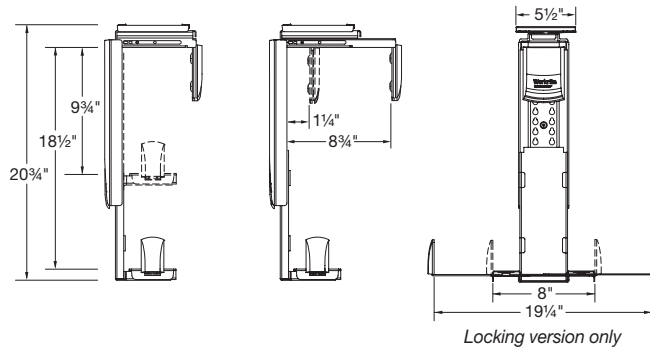

Volume range

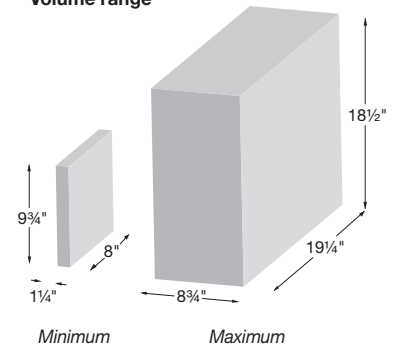

Mounting Options:

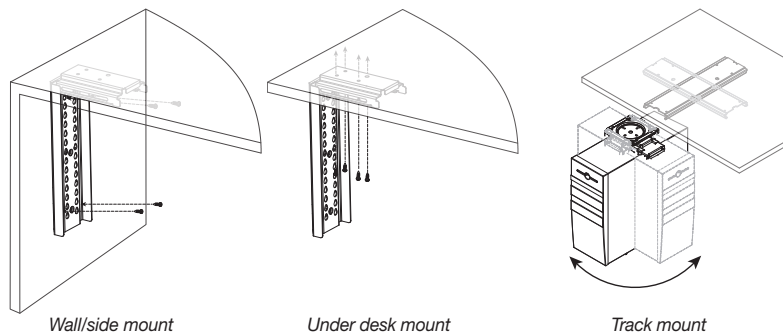

Mounting	Model#	Weight	LEED ♻️ %
Fixed Mount, Non-Locking	920-F	6	27
Fixed Mount, Locking	920-FL	7	26
Track Mount, Non-Locking	920-T	8	29
Track Mount, Locking	920-TL	9	28
Lock Kit	920-LK	1	



Workrite Ergonomics, Inc. 1450 Technology Lane, Petaluma, CA 94954
www.workriteergo.com 800.959.9675

©2011 Workrite Ergonomics | All referenced company and product names are trademarks, registered trademarks or copyrights of their respective holders.
1400226-0711 Subject to change without notice.

Workrite
ergonomics®